

ProReact EN Digital Linear Heat Detection Cable

Installation Instructions

Contents:

Important Guidelines – read before commencing installation	Page 3
General Overview	Page 4
Product Features	
Technical Data	
Detection Temperatures & Coatings	
Chemical Resistance	
Technical Specifications	Page 5
Typical System Configurations	Page 6
Addressable Fire Alarm Systems	
ProReact Digital Sensor Control Unit (DSCU-EN)	
Installation Specifications	Page 7
Leader Cable	
Ambient Temperature	
Low Temperature Installation Considerations	
Installation Hardware	Page 8
Splicing	Page 10
Testing and Verification	Page 10
Glossary	Page 11

Important Guidelines

Please read this instruction leaflet thoroughly before commencing installation.

- ✓ Install the Digital Linear Heat Detection Cable accordingly to meet local and country installation requirements.
- ✓ Thermocable Digital Linear Heat Detection Cable must be installed by a qualified professional in accordance with BS 5839-1:2017 (or country equivalent) and IEC 60364 and authorities having jurisdiction.
- ✓ Support the detection cable at 0.6m (2ft) to 1.5m (5ft) intervals.
- ✓ Using a multimeter, test the detection cable **on the reel before** installation.
- ✓ Ensure the maximum ambient temperature rating of the detection cable will not be exceeded during transport, storage or normal operating conditions.
- ✓ Ensure adjacent runs of detection cable are spaced at less than or equal to the maximum approved spacing.
- ✓ Ensure the detection cable is not in contact with any material which may conduct heat onto the cable directly.
- ✓ A silicone sleeve should be placed between fixing clips and linear heat detection cable.
- ✓ Ensure any cable glands used are tightened to form a secure and moisture proof seal around the detection cable.

 Avoid allowing the detection cable to come in contact with any material which acts as a heat sink. This may delay the activation of the cable in alarm situations.

 Do not connect two lengths of detection cable which have different action temperatures.

 Do not connect lengths of fixed temperature cable in 'T' connections or spurs.

 Do not paint the detection cable

 Do not place the detection cable under excessive tension.

 Do not bend the detection cable at right angles. The minimum bend radius is 100mm (4").

 Avoid subjecting the detection cable to mechanical damage which could result in false activation.

 Avoid laying the detection cable in areas where heavy traffic may result in the cable being crushed.

General Overview

Thermocable ProReact EN Digital Linear Heat Detection (LHD) cable uses fixed temperature detection technology to provide a straightforward method for sensing changes in temperature. The cable can offer alternative overheat protection in a vast range of applications and environments, from tunnels, cable trays, warehousing to sensing changes in temperature within escalators and other applications where many risks of fire are hidden from view.

ProReact EN Digital LHD cable is a non-resettable line-type heat detector. The two twisted cores and held apart by an advanced temperature sensitive polymer. At a temperature, set by the manufacturing processes of the cable, the temperature sensitive polymer surrounding the two cores softens, allowing the cores to come into contact. This is an irreversible process and once the cable has activated, the section which has triggered must be cut out and replaced (not the whole cable).

Digital Sensor Control Unit (DSCU-EN)

The ProReact EN Digital LHD cable has been approved to EN54-28:2016 in conjunction with the ProReact Digital Sensor Control Unit (DSCU-EN). The DSCU-EN monitors up-to two zones of Digital LHD cable and has separate fault and alarm outputs for each zone. It is straightforward to connect the DSCU-EN to a conventional fire alarm panel or to an addressable system using an I/O, zone or switch monitor module. It also has a built-in display which shows the state of each zone, including the distance in metres and feet to the alarm point, if an alarm is triggered. Furthermore, an RS-485 Modbus RTU/ASCII output is available as standard for integration with a PLC or SCADA system.

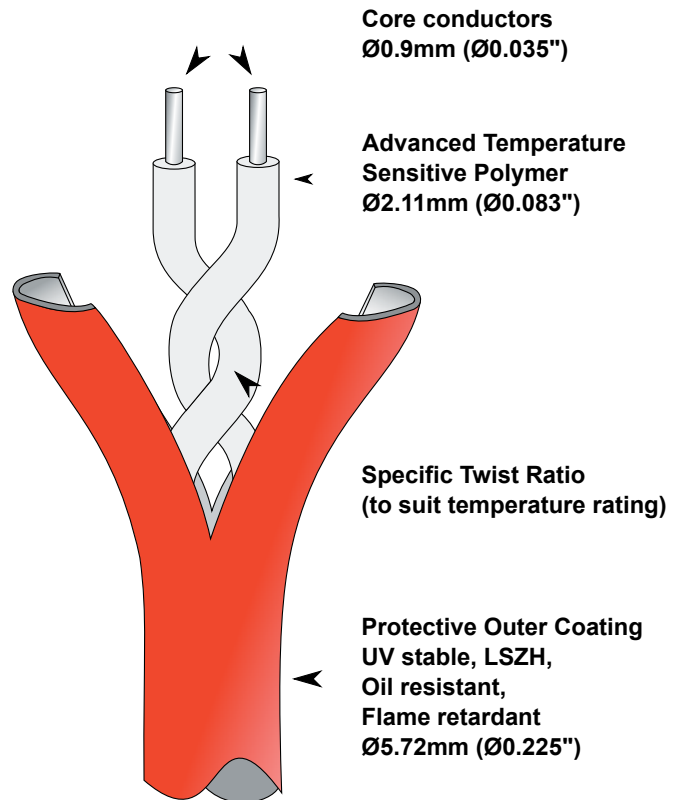

Figure 1. ProReact EN Digital LHD Cable Construction

Product Features

- EN54-28:2016 approved
- CE Marked
- RoHS compliant
- Up-to 1,000m (3,280ft) per zone (when used with the DSCU-EN)
- Fixed sensitivity and detection along the entire length of sensor cable
- Low smoke and halogen free. Flame retardant.
- UV stable and hydrocarbon resistant.
- Optional stainless steel over-braiding for increased mechanical protection

Technical Data

Product type:	Non-resettable line-type heat detector
Construction:	Overall insulated, twisted pair of stainless steel cores
Insulation:	1kV tested protective outer coatings
Additional insulation options:	Stainless Steel over-braiding
Approvals:	EN54-28:2016, CE Marked, RoHS Compliant
Maximum Zone Length:	1,000m (3,280ft) (when used with DSCU-EN)
Wire Overall Diameter:	5.72mm (0.225in)
Minimum bend radius:	100mm (4")
Electrical	
Max Voltage Rating:	49Vac, 74Vdc
Resistance:	approx 1.25ohms per metre per core

Technical Specifications

Detection Temperatures & Coatings

A stainless steel outer braid is available on the entire range of Thermocable's ProReact EN Digital LHD cable and provides extra mechanical protection to the inner detection cable without impeding on the performance of the detection cable. It is frequently installed in abrasive environments.

Please Note: ProReact EN Digital LHD cable with Stainless Steel braiding has not been evaluated to EN54-28.

Product	ProReact EN Digital LHD Cable - EN78	ProReact EN Digital LHD Cable - EN88
UL File No	S36157	
UL Model Designation	EN78	EN88
Thermocable Part No	F1180	F1181
Description	ProReact EN Digital LHD Cable – 78 deg C	ProReact EN Digital LHD Cable – 88 deg C
EN54-28 Performance Type	T078-V10-A045	T088-V10-A065
EN54-28 Environmental Group	II	
Nominal Activation Temperature	78 deg C	88 deg C
Maximum Ambient Temperature	45 deg C	65 deg C
Minimum Ambient Temperature	-40 deg C	
Humidity	0% to 98% RH	
Colour	Red	White
Capacitance per m	<100pF	
Inductance per m	<3.2µH	
Resistance per m	Approx 2.5ohms	
Diameter	5.72mm +/- 0.12mm (0.225" +/- 0.005")	
Minimum bend radius	100mm (4")	
Features	Low-Smoke Zero Halogen (LSZH), UV Stable, Oil resistant, Flame retardant	
Chemical Resistance	These ratings are given as a guide and for constant exposure to the chemicals shown at normal (10 to 30 deg C) temperatures. (* - not recommended, ***** - little or no impact)	
Ammonia, Liquid / Gas	*****	
Butane	**	
Copper Nitrate	*****	
Fuel Oils	***	
Gasoline	***	
Hydrofluoric Acid	****	
Kerosene	*	
Diesel Fuel	***	
Acetic Acid	****	

Technical drawings of ProReact EN Digital Linear Heat Detection Cable are available upon request.

Typical System Configurations

The ProReact EN Digital LHD cable is designed to work with the ProReact Digital Sensor Control Unit (DSCU-EN) and ProReact Digital End-of-Line Unit (EOLU-EN). The ProReact DSCU-EN has been specifically designed to monitor the ProReact EN Digital LHD Cable and be immune to any electro-magnetic interference that may be present in the typical applications the cable is installed into.

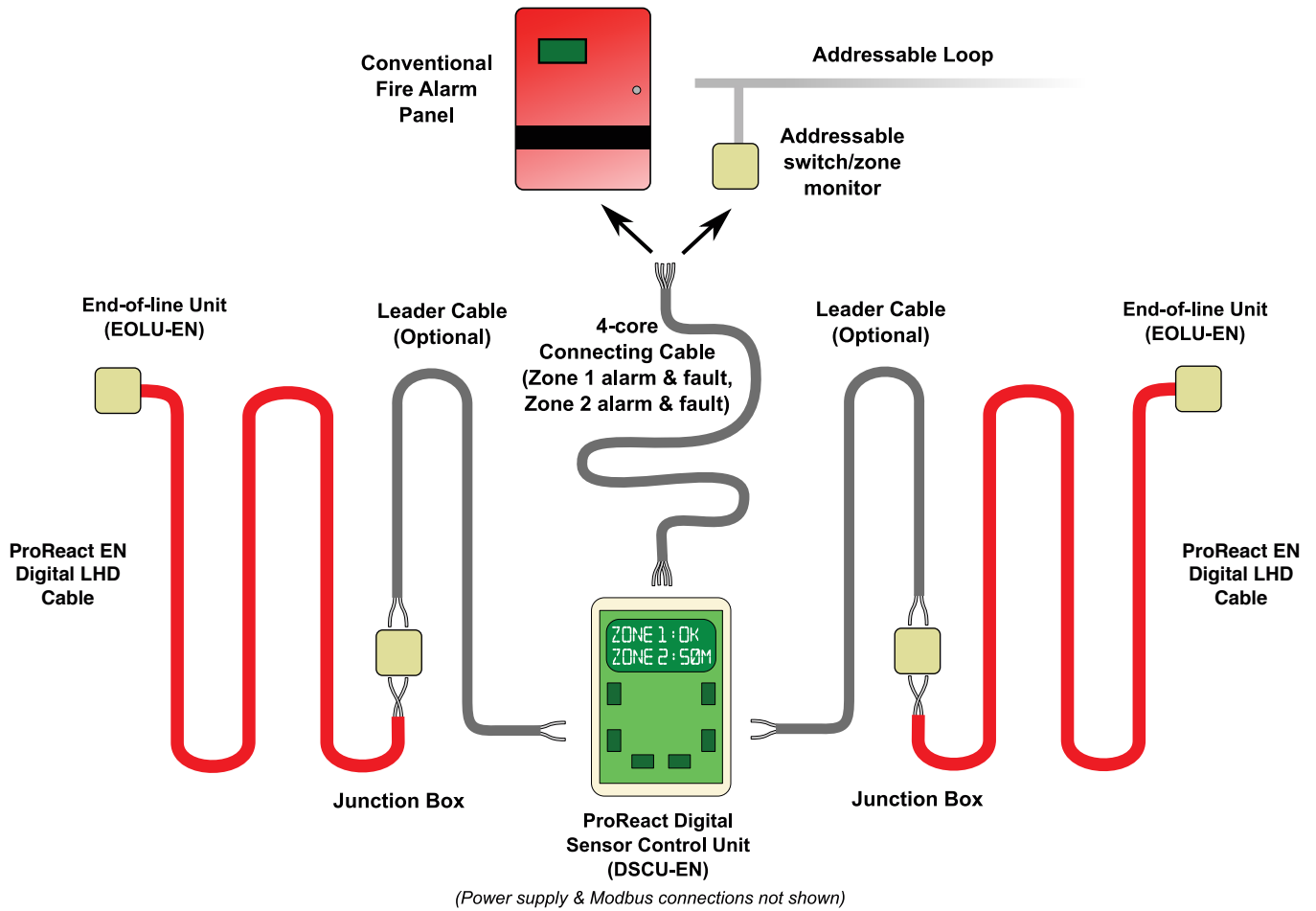

Figure 1: Typical Installation of the ProReact Digital Sensor Control Unit

Installation Specifications

Leader Cable

An approved type of leader cable, preferably Fire Rated cable, should be used between the fire alarm control panel or addressable switch/zone monitor and the Digital Linear Heat Detection Cable. A secure waterproof (IP65 or greater) junction box must be used to connect the leader cable to the detection cable. It is recommended that leader cable with the following minimum cross sectional area (CSA) per conductor is used when using the maximum length of detection cable. Consult with the authority having jurisdiction and the fire alarm control panel manufacturer for further information.

Recommended Maximum Leader Cable Length and CSA for copper conductors (with maximum length of Linear Heat Detection Cable 1km/3.28kft)

0.8 mm² (18AWG) — Upto 1,000m (3,280ft)

Low Temperature Installation Considerations

Fixed temperature Linear Heat Detection cable is suitable for use in ambients down to -40°C (-40°F). Such conditions occur in cold storage freezer warehouses and outdoors for example.

Take special care when installing LHD cable in low ambients or for use in low temperature conditions careful consideration of the conditions and environment should be undertaken.

Wherever possible the LHD cable should not be installed when the ambient temperature is below -10°C (14°F). The materials within the cable will become less flexible and are more prone to damage. If the ambient temperature is likely to drop significantly after installing the cable take into account linear shrinkage of the cable when attaching support brackets. The cable can shrink in length by 12% at -40°C (-40°F).

A silicone pad should be placed around the cable before clipping into the support bracket. This prevents damage to the cable and reduces the heat sink effect of the clip.

The minimum bend radius of the detection cable should be increased to 150mm (6") to account for the reduced flexibility. The maximum distance between support brackets should be no more than 1m (3ft) and it is important to support the cable close to either side of any bend.

Ensure any junction boxes other enclosures are waterproof and suitable for the expected operating temperatures.

Installation Hardware

There are many applications where Digital Linear Heat Detection Cable is used to provide protection. Please refer to the ProReact Linear Heat Detection Applications Guide for more information on the types of fittings which should be used. The list is not exhaustive, however, any fitting not mentioned in the Application Guide which may be used should be evaluated to ensure it is fit for purpose. Consult the authority having jurisdiction for more information.

The Digital Linear Heat Detection Cable should be adequately supported to prevent sagging. Ideally cable supports should be placed every 1m (3ft) and no more than 1.5m (5ft) apart. It may be necessary to place more supports around corners and other transition areas.

Care should be taken when mounting the cable in clips (or equivalent) that they are not done so tight as to crush the cable. The detection cable should be held firmly without deformation. Avoid placing excessive tension in the cable, no greater than 50N. Ensure also that the minimum bend radius is observed at all times – 100mm (4").

It is of particular importance to use a silicone pad between the heat sensing cable and the fixing clip if the metal clip is exposed to the sun or attached to a piece of equipment which may get hot and transfer the heat to the cable. See a typical mounting configuration in the image below.

Where possible, it is preferable to install the Digital Linear Heat Detection Cable in one continuous run of cable with as few splices as possible.

When pulling the detection cable from a reel, a reel stand must be used. Do not pull the cable off the reel vertically with the reel stationary as this will twist and damage the cable. A guide wire may be required for installations where supporting the cable at the recommended spacing is not practical. Ensure the diameter or gauge of the guide wire is adequate for the distance which is being spanned. Commercially available stainless steel wire with a diameter of approximately 2mm is suitable for use as a guide wire.

Connections into junction boxes and other enclosures must use strain relief connectors which provide dust and moisture protection (IP65 or greater protection). The standard diameter of detection cable is 5.72mm (0.225"). Suitable cable glands are shown below which fit an M12 standard knockout.



Figure 4: Typical Cable Glands for connection Digital Linear Heat Detection Cable into an enclosure

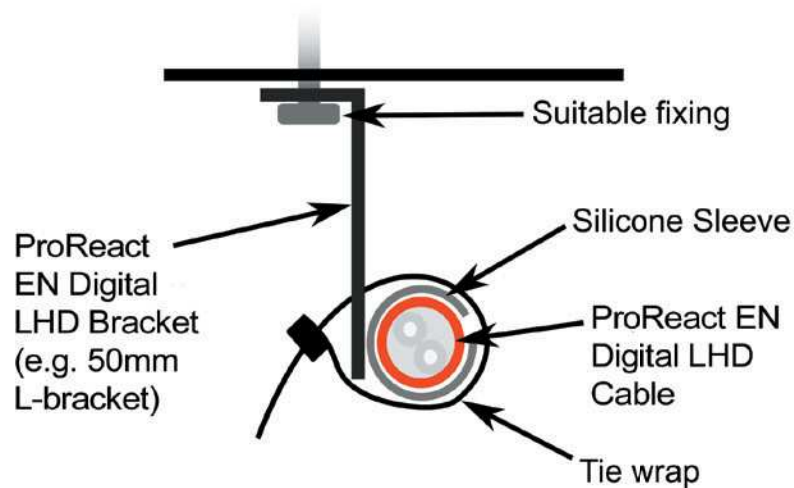

Area Protection

Thermocable Digital Linear Heat Detection Cable is suitable for broad or wide area detection of overheat or fire conditions, e.g. warehouses etc. The Digital LHD cable should be installed with a minimum distance between the cable and the ceiling of 20mm to allow hot gases rising from an event to trigger the detection cable.

Maximum support spacings should be followed (see illustration right) and the cable securely attached to the ceiling or beams. Section 22.6 of BS 5839-1 (or country equivalent) should be consulted for guidelines of installing line-type heat detectors. The main point to consider is that no point in the protected space is further than 5.3m from the nearest point on a line-type heat detector. However, this value may change for sloped ceilings and ceilings which have closely spaced structural beams, for example. For an application which has a smooth ceiling, this means the maximum spacing between runs of LHD cable is as follows:

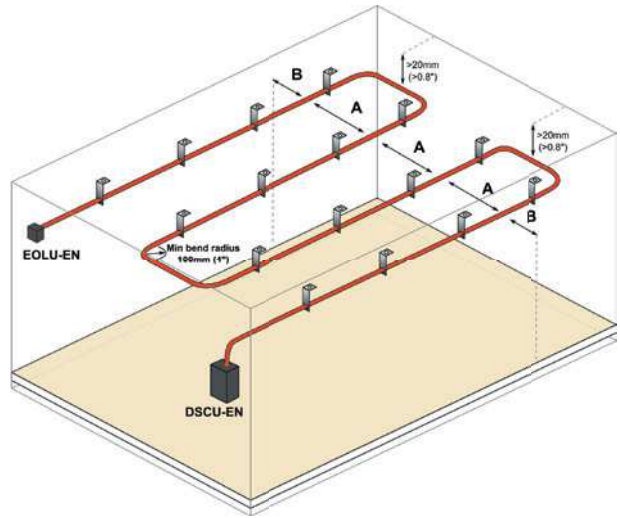

for ceilings up-to	Spacing between runs (A)	Recommended minimum spacing to wall, partition or obstruction (B)
3.75m in height	7.5m	0.5m
4.5m in height	5.6m	0.5m
5m in height	3.5m	0.5m

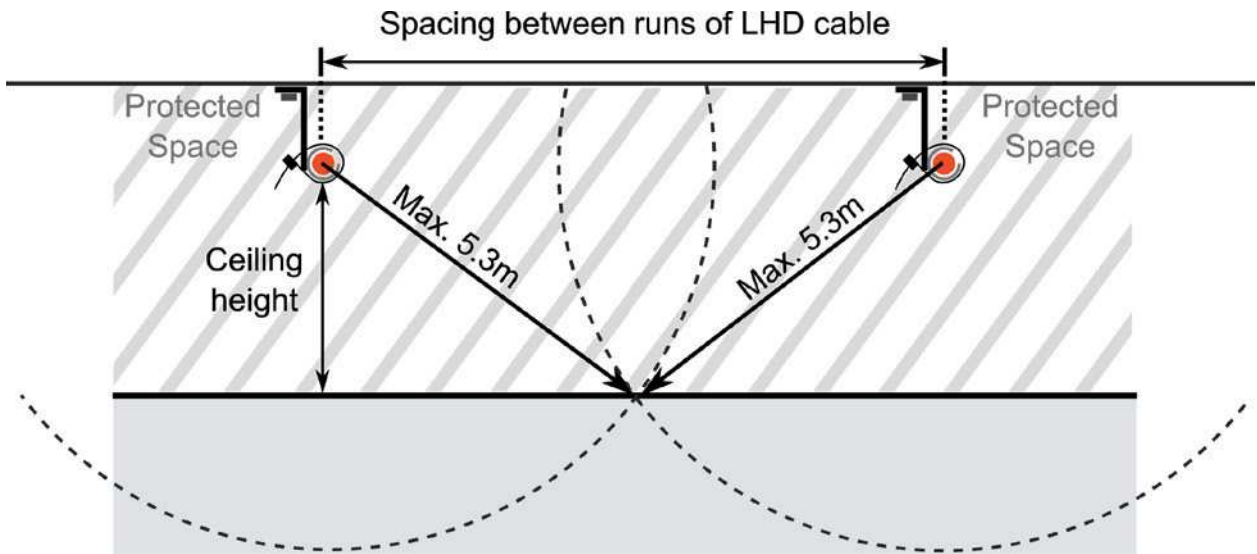

Splicing

If the non-resettable Digital Linear Heat Detection Cable gets damaged or has triggered due to an overheat condition, the section can be removed and a new section spliced in its place.

Care should be taken during splicing to ensure the two core conductors do not come into contact with each other at any point and the final spliced joint is secure and made waterproof. It is recommended junction box is used, with an IP rating suitable for the environment, to join two lengths of LHD cable together. Do not solder the two cores of the LHD cable together. A secure connection should be made with DIN rail mounted terminal blocks or equivalent.



When replacing a section of the detection cable due to an overheat condition having occurred, the section including at least 3m (10ft) either side of the known event should be replaced.

Testing and Verification

Routine maintenance and checking should be carried out to ensure the Digital Linear Heat Detection Cable will function as expected and has not been damaged etc.

A visual inspection should be performed to ensure all support brackets and other aspects of the physical installation are suitable. The cable should also be visually checked for damage to the outer or inner insulation. Check to make sure the silicone pads are correctly installed around the cable in the clips.

Any joints which have been made should be checked to make sure they are secure.

Electrical tests should be carried out to determine the circuit created by the conductors is working. Remove the conductors from the fire alarm control panel or addressable switch monitor and measuring the resistance across them. The resulting value should equal the end-of-line resistance plus approximately 1250Ω/km for each leg.

To test in circuit with a fire alarm control panel or addressable switch monitor re-attach the Digital LHD cable.

Shorting out the End of Line device should put the system into alarm. Disconnecting either leg from the end of line device should put the system into fault.

Functional testing

Fixed Temperature Digital Linear Heat Detection Cable is non-restorable – any section which has alarmed must be cut out and replaced. Therefore functional testing of the installed cable will not normally be carried out. However, if required, any Digital LHD cable leftover after installation can be used to periodically perform a functional test. A 1m (3ft) section of cable should be attached between the end of the Digital LHD cable run and the end-of-line device.

Using a suitable device heat the test length of detection cable up. Once the action temperature (including any tolerances) has been reached the system should alarm.

Ensure the test length is removed before placing the system back into normal operation.

Glossary

Alarm condition – A fire or overheat around the Digital LHD cable which activates the cable and triggers the DSCU.

Cable glands – Used to form a dust-proof and weatherproof seal around a cable entering the DSCU unit.

Detection temperature – The nominal temperature at which the cores in the LHD cable irreversibly come into contact.

Digital linear heat detection cable – A sensing cable comprised of a pair of twisted conductors that fuse together at a specific temperature and induce an alarm on a fire panel via the DSCU.

End of line resistor – A component which allows a residual current flow through a circuit to monitor the integrity of the circuit. In the event of a break in the circuit, current will stop flowing completely and a trouble or fault signal will be triggered.

Fault condition – A break in one or both cores of the Digital LHD cable or a malfunction of the DSCU.

Junction box – A secure, dust-proof and weatherproof enclosure to protect a join between two lengths of Digital LHD cable or a length of Digital LHD cable and leader cable.

Leader cable – A non-temperature sensing cable which transmits the signals between two components in the system, e.g. the DSCU and the Digital LHD cable. Does not provide fire detection and may be fire-rated to continue functioning even in a fire condition.

Maximum ambient temperature – The maximum allowed temperature which should be experienced in normal operating conditions around the Digital LHD cable.

Spacing – The distance between adjacent runs of LHD cable on a ceiling, for example.

Two-wire RS-485 Modbus RTU/ASCII Communications – An industry standard, signalling protocol used to communicate information between components in a system, for example a SCADA system or PLC. Often used to provide more information to be communicated than simple open or closed status communicated by a relay output.

Zone – A single circuit of ProReact linear heat detection cable connected across either a ProReact DiMM or a fire panel and an end of line resistor

ASTEC B.V.

Kerkweg 70
6155 KN Puth (NL)
Tel.: +31 (0)46 443 55 77
Fax: +31 (0)46 443 04 82
E-mail: info@astec.nl
Internet: www.astec.nl