

ProReact Digital Fixed Temperature Linear Heat Detection Cable

Installation Instructions

Also known as

- **ProReact Digital Linear Heat Sensing Cable**
- **ProReact Digital LHD Cable**
- **ProReact Digital LHS Cable**

Contents:

Important Guidelines – read before commencing installation	Page 3
Introduction	Page 4
Features	
Technical Data	
Technical Specifications	Page 5
Typical System Configurations	Page 6-7
Conventional Fire Alarm Systems	
Addressable Fire Alarm Systems	
Alarm Point Distance Locator	
Installation Specifications	Page 7
Leader Cable	
Detection Cable	
Installation Hardware	Page 8
Area Protection	Page 8
Low Temperature Installation Considerations	Page 9
Splicing	Page 9
Testing and Verification	Page 10
Chemical Resistance Chart	Page 10
LHD Weights and Dimensions	Page 11

Important Guidelines

Please read this instruction leaflet thoroughly before commencing installation.

- ✓ Install the linear heat detection cable accordingly to meet local and country installation requirements.
- ✓ Thermocable linear heat detection cable must be installed in accordance with NFPA 70 & 72, NEC 760 (National Electric Code) and Authorities Having Jurisdiction.
- ✓ Support the detection cable at 1m (3ft) to 1.5m (5ft) intervals.
- ✓ Test the detection cable before installation using a multimeter.
- ✓ Ensure the maximum ambient temperature rating of the detection cable will not be exceeded during storage or normal operating conditions.
- ✓ Ensure the detection cable is spaced at less than or equal to the maximum approved spacing.
- ✓ Ensure the detection cable is not in contact with any material which may conduct heat onto the cable directly.
- ✓ A silicone pad should be placed between the fixing clip and heat sensing cable.
- ✓ Ensure any cable glands used are tightened to form a secure and moisture proof seal around the detection cable.

- ⚠ Avoid allowing the detection cable to come in contact with any material which acts as a heat sink. This may delay the activation of the cable in alarm situations.
- ⚠ Do not exceed the maximum operating voltage of the detection cable (48Vdc).
- ⚠ Do not connect two lengths of detection cable which have different action temperatures.
- ⚠ Do not connect lengths of fixed temperature cable in 'T' connections or spurs.
- ⚠ Do not paint the detection cable
- ⚠ Do not place the detection cable under excessive tension.
- ⚠ Do not bend the detection cable at right angles. The minimum bend radius is 2" or 50mm.
- ⚠ Avoid subjecting the detection cable to mechanical damage which could result in false activation.
- ⚠ Avoid laying the detection cable in areas where heavy traffic may result in the cable being crushed.

Introduction

Thermocable ProReact Digital Linear Heat Detection Cable uses fixed temperature detection technology to provide an easy method for sensing changes in temperature levels. The cable can offer alternative overheat protection in a vast range of applications and environments, from tunnels, cable trays, warehousing to sensing changes in temperature within escalators and other applications where many risks of fire are hidden from view.

The digital linear heat detection cable can be directly connected to a single zone of a conventional fire alarm control panel, or, using an addressable zone/switch monitor, the digital linear heat detection cable can easily be interfaced to an addressable loop.

Digital linear heat detection cable is comprised of a pair of twisted low resistance, tri-metallic conductors, sheathed in advanced temperature sensitive polymers. When the cable reaches the required temperature the two twisted cores will fuse together, with a fire triggering resistor attached to the input interface and a single core of linear heat cable to activate an alarm at the main fire panel (see schematic).

Digital Interface Monitor Module

A UL864 10th edition approved Digital Interface Monitor Module is available and provides additional benefits when used with the ProReact Digital LHD cable. It can simultaneously monitor up to two zones of LHD cable and has separate fault and alarm outputs for each zone. A built in display shows the state of each zone, including the distance in meters and feet to the alarm point if an alarm is triggered. It also includes an RS-485 Modbus RTU output for integration with a PLC or SCADA system.

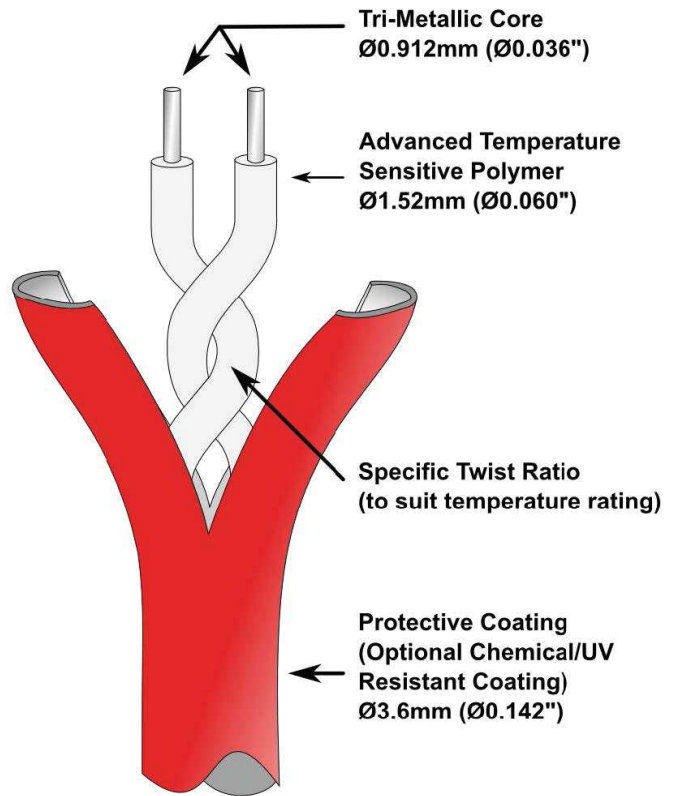

Figure 1: Fixed Temperature Linear Heat Detection Cable Construction

Features

- cUL/UL 521 Approved (File No. S8976)
- FM Approved (Class 3210)
- CE Marked
- Up to 10,000ft (3000m) per zone
- Detection along the entire length of sensor cable
- Optional Nylon extrusion offering UV protection and increased durability for outdoor use
- Optional Polypropylene extrusion for increased chemical protection in caustic environments
- Optional stainless steel over-braiding for increased mechanical protection

Detection Temperatures

- 68°C (155°F)
- 78°C (172°F)
- 88°C (190°F)
- 105°C (221°F)
- 185°C (365°F)

Technical Data

Construction:	Overall insulated, twisted pair of tri-metallic cores
Insulation:	1kV tested protective outer coat
Additional Insulation Options:	Nylon, Polypropylene or Stainless Steel braiding
Approvals:	CE Marked, RoHS Compliant, FM, UL, GOSTR
Maximum Zone Length:	3,000m (10,000ft)
Wire Overall Diameter:	3.60mm to 5.08mm (0.142" to 0.200")
Minimum bend radius:	50 mm (2")
Ambient Temperature Range:	-40°C – 125°C (-40°F – 257°F) (dependant upon action temperature)

Electrical

Max Voltage Rating:	30Vac, 42Vdc
Resistance:	~100Ω/km (29Ω/kft) per leg
Velocity of Propagation:	~55%
Capacitance:	88 – 150 pF/m (26 – 45 pF/ft)
Inductance:	540 – 1050 nH/m (165 – 320 nH/ft)

Technical Specifications

Electrical Specifications

Operating Voltage Range	0-30Vac, 0-42Vdc
Resistance	Approx 100Ω/km (30.4Ω/kft) per leg
Velocity of Propagation	Approx 55%
Capacitance	88 – 150pF/m
Inductance	540 – 1050nH/m

Environmental Specifications

Maximum ambient temperature	
68°C, 78°C	45°C (113°F)
105°C, 88°C	65°C (149°F)
185°C	125°C (257°F)
Humidity	0% to 100% RH
Minimum Operating Temperature -40°C (-40°F)	

Mechanical Specifications

Material	Overall insulated, twisted pair of tri-metallic cores
Colour	(additional nylon coating is always black) (additional polypropylene coating is transparent)
68°C, 78°C	Red
88°C, 105°C	White
185°C	Red
Diameter (all)	
PVC coating	3.60mm +/- 0.12mm (0.142" +/- 0.005")
...with additional Polypropylene coating	4.44mm +/- 0.12mm (0.175" +/- 0.005")
...with additional Nylon coating	4.50mm +/- 0.12mm (0.177" +/- 0.005")
...with additional Stainless Steel Braid	4.10mm +/- 0.12mm (0.161" +/- 0.005")
...with additional Nylon Coating & Stainless Steel Braid	5.08mm +/- 0.12mm (0.200" +/- 0.005")

Typical System Configurations

Conventional Fire Alarm Systems

Thermocable ProReact Linear Heat Detection (LHD) cable should be connected to the initiating device circuit on a conventional fire alarm control panel. Leader cable may be used between the beginning of the LHD cable and the fire alarm control panel if the area requiring protection is some distance away from the control panel. A junction box should be used to connect the leader cable to the linear heat detection cable to ensure a secure, waterproof electrical connection.

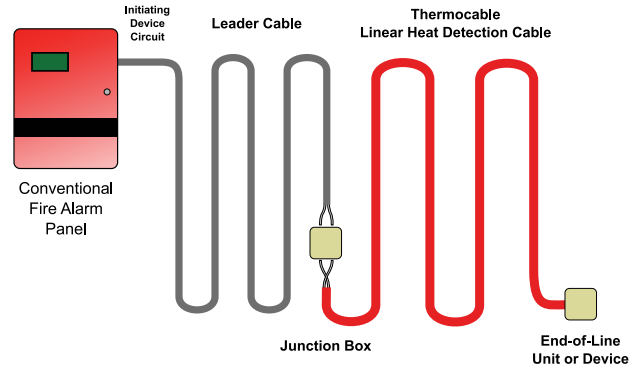

Figure 1: Typical Wiring Configuration Conventional System

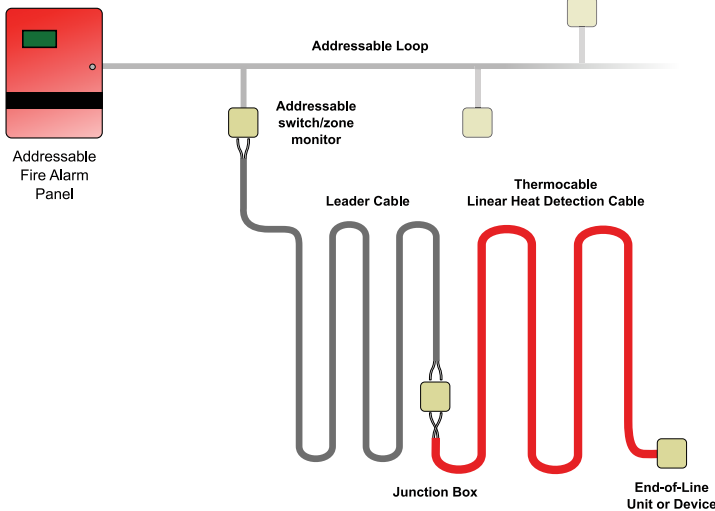

Figure 2: Typical Wiring Configuration Addressable System

Addressable Fire Alarm Systems

When used as part of an addressable system, Thermocable ProReact Linear Heat Detection cable should be connected onto the addressable loop using a switch or zone monitor. External power is not required for the Linear Heat Detection cable. Leader cable may be used between the beginning of the LHD cable and the addressable switch or zone monitor if the area requiring protection is some distance away. A junction box should be used to connect the leader cable to the linear heat detection cable to ensure a secure, waterproof electrical connection.

Typical Wiring Connection

Open circuit on LHD cable = fault.
Overheat/Fire on LHD cable = alarm

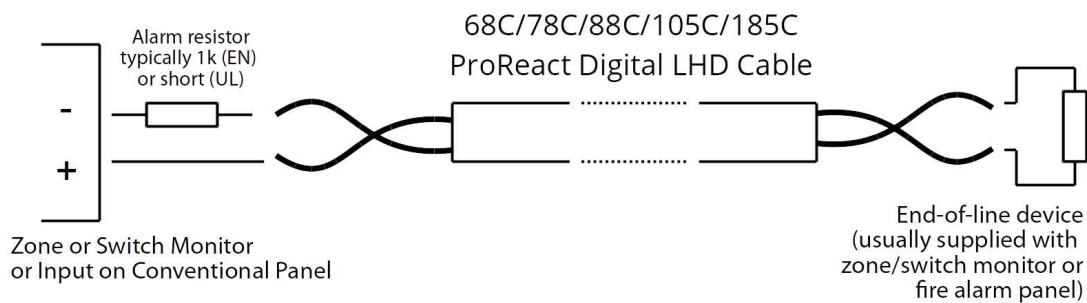

Typical System Configurations (cont.)

Digital Interface Monitor Module

A Digital Interface Monitor Module (DiMM) is available for use with Thermocable ProReact Digital Linear Heat Detection Cable. The DiMM can simultaneously monitor up to two zones of Digital LHD cable and provides additional benefits to using LHD cable, including:

- Ability to provide a pre-alarm and alarm signal to a fire alarm panel (using two LHD cables with different action temperatures)
- Fail-safe alarm activation (using two LHD cables with the same action temperature, both must alarm for the fire alarm system to trigger an alarm)
- RS-485 Modbus RTU output for connection to a PLC or SCADA system.
- The DiMM has a built in display which shows the state of each zone and automatically displays the distance in metres and feet to the alarm point if an alarm is triggered.

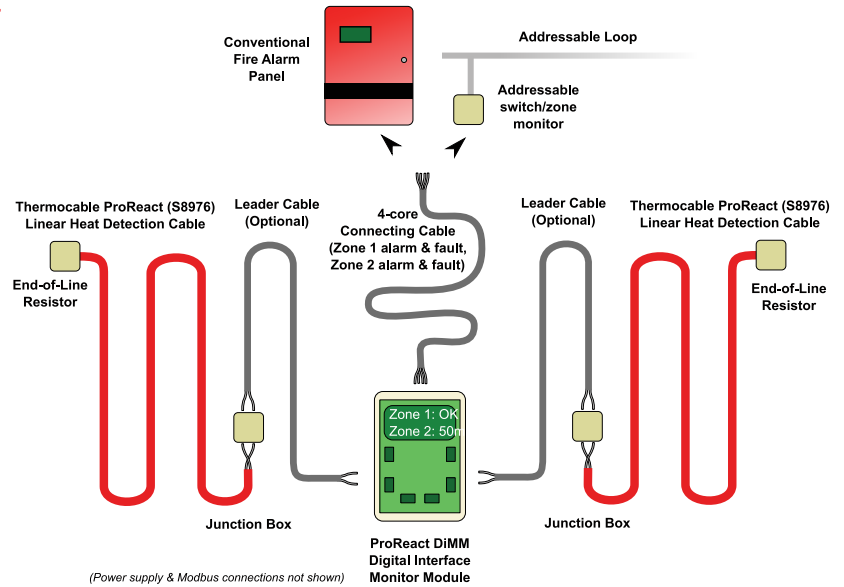

Figure 3: Typical Wiring Configuration with Digital Interface Monitor Module

Leader cable between the DiMM and the Linear Heat Detection cable can be calibrated out at the commissioning stage. Refer to the DiMM manual for more information.

Mapping of the system is important when using a Digital interface Monitor Module. During installation draw a map to associate distances along the detection cable to locations within a building/warehouse etc. This will aid in locating the area requiring attention in an alarm condition.

Installation Specifications

Leader Cable

An approved type of leader cable, preferably Fire Rated cable, should be used between the fire alarm control panel or addressable switch/zone monitor and the Linear Heat Detection cable. A secure waterproof (IP65 or greater) junction box must be used to connect the leader cable to the detection cable. It is recommended that leader cable with the following minimum cross sectional area (CSA) per conductor is used when using the maximum length of detection cable. Consult with the authority having jurisdiction and the fire alarm control panel manufacturer for further information.

Recommended Maximum Leader Cable Length and CSA for copper conductors (with maximum length of Linear Heat Detection Cable 3km/10kft)

0.8 mm² (18AWG) —	Upto 2,500m (8,200ft)
1.3 mm² (16AWG) —	Upto 3,500m (11,500ft)
2.0 mm² (14AWG) —	Upto 6,000m (20,000ft)
3.3 mm² (12AWG) —	Upto 9,500m (31,000ft)

Detection Cable

A very important factor in determining which rating of fixed temperature linear heat detection (LHD) cable to use is the maximum ambient temperature the cable will be exposed to. To provide the fastest alarm response but lowest possibility for false alarms the detection cable with the lowest action temperature above the maximum ambient temperature should be chosen. For example, if the maximum ambient temperature is determined to be 55°C (131°F), a detection cable with an action temperature of 88°C (190°F) should be chosen (if the fastest possible response time is required).

Maximum Ambient Temperature	Available Action Temperatures
Up to 45°C (113°F)	68°C (155°F), 78°C (172°F)
Up to 65°C (149°F)	88°C (190°F), 105°C (221°F)
Up to 125°C (257°F)	185°C (365°F)

Installation Hardware

There are many applications where Linear Heat Detection cable is used to provide protection. Please refer to the ProReact Linear Heat Detection Applications Guide for more information on the types of fittings which should be used. The list is not exhaustive, however, any fitting not mentioned in the Application Guide which may be used should be evaluated to ensure it is fit for purpose. Consult the authority having jurisdiction for more information.

The linear heat detection cable should be adequately supported to prevent sagging. Ideally cable supports should be placed every 1m (3ft) and no more than 1.5m (5ft) apart. It may be necessary to place more supports around corners and other transition areas.

Care should be taken when mounting the cable in clips (or equivalent) that they are not done so tight as to crush the cable. The detection cable should be held firmly without deformation. Avoid placing excessive tension in the cable, no greater than 50N. Ensure also that the minimum bend radius is observed at all times – 50mm (2").

It is of particular importance to use a silicone pad between the heat sensing cable and the fixing clip if the metal clip is exposed to the sun or attached to a piece of equipment which may get hot and transfer the heat to the cable.

Where possible, it is preferable to install the linear heat detection cable in one continuous run of cable with as few splices as possible.

When pulling the detection cable from a reel, a reel stand must be used. Do not pull the cable off the reel vertically with the reel stationary as this will twist and damage the cable. A guide wire may be required for installations where supporting the cable at the recommended spacing is not practical. Ensure the diameter or gauge of the guide wire is adequate for the distance which is being spanned. Commercially available stainless steel wire with a diameter of approximately 2mm is suitable for use as a guide wire.

Connections into junction boxes and other enclosures must use strain relief connectors which provide dust and moisture protection (IP65 or greater protection). The standard diameter of detection cable is 3.6mm (0.142") to 5.08mm (0.200"). Suitable cable glands are shown opposite which fit an M12 standard knockout.



Figure 4: Typical Cable Glands for connection Linear Heat Detection cable into an enclosure

Area Protection

Thermocable Linear Heat Detection cable is suitable for broad or wide area detection of overheat or fire conditions, e.g. warehouses etc. The LHD cable should be installed with a minimum distance between the cable and the ceiling of 20mm to allow hot gases rising from an event to trigger the detection cable.

Maximum support spacings should be followed (see illustration right) and the cable securely attached to the ceiling or beams. For ceilings up 9m (30ft) in height maximum spacing between runs should be as in the table below. For ceilings over 9m (30ft) in height the spacings should be halved. The corresponding value in the table below should be halved for spacing between walls/partitions etc. and a run of detection cable.

Thermocable LHD Action Temperature	UL/cUL	FM
68°C (155°F), 78°C (172°F)		
88°C (190°F)	10m (35ft)	9m (30ft)
105°C (221°F)	10m (35ft)	7.5m (25ft)

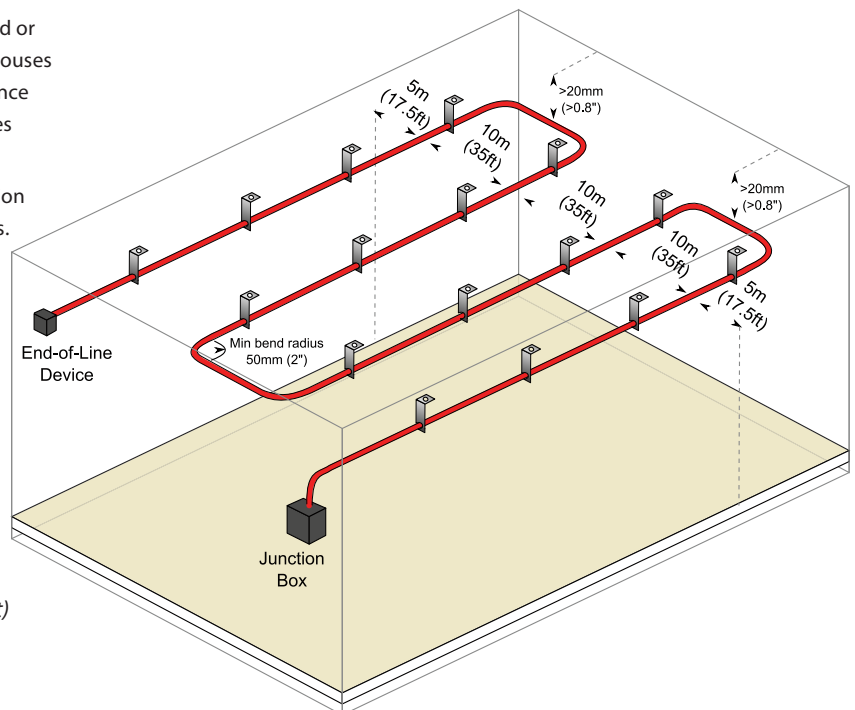

Low Temperature Installation Considerations

Fixed temperature Linear Heat Detection cable is suitable for use in ambients down to -40°C (-40°F). Such conditions occur in cold storage freezer warehouses and outdoors for example.

Take special care when installing LHD cable in low ambients or for use in low temperature conditions careful consideration of the conditions and environment should be undertaken.

Do not install the LHD cable when the ambient temperature is below -10°C (14°F). The materials within the cable will become less flexible and are more prone to damage. If the ambient temperature is likely to drop significantly after installing the cable take into account linear shrinkage of the cable when attaching support brackets. The cable can shrink in length by 12% at -40°C (-40°F).

A silicone pad should be placed around the cable before clipping into the support bracket. This prevents damage to the cable and reduces the heat sink effect of the clip.

The minimum bend radius of the detection cable should be increased to 100mm (4") to account for the reduced flexibility. The maximum distance between support brackets should be no more than 1m (3ft) and it is important to support the cable close to either side of any bend.

Ensure any junction boxes other enclosures are waterproof and suitable for the expected operating temperatures.

Splicing

If the fixed temperature linear heat detection cable gets damaged or has triggered due to an overheat condition, the section can be removed and a new section spliced in its place.

Care should be taken during splicing to ensure the two core conductors do not come into contact with each other at any point and the final spliced joint is secure and made waterproof. A junction box can be used if required however it is also acceptable to splice together two ends of detection cable using a connection box and seal the splice using sealant tape (see figure 11).

 **When replacing a section of the detection cable due to an overheat condition having occurred, the section including at least 3m (10ft) either side of the known event should be replaced.**

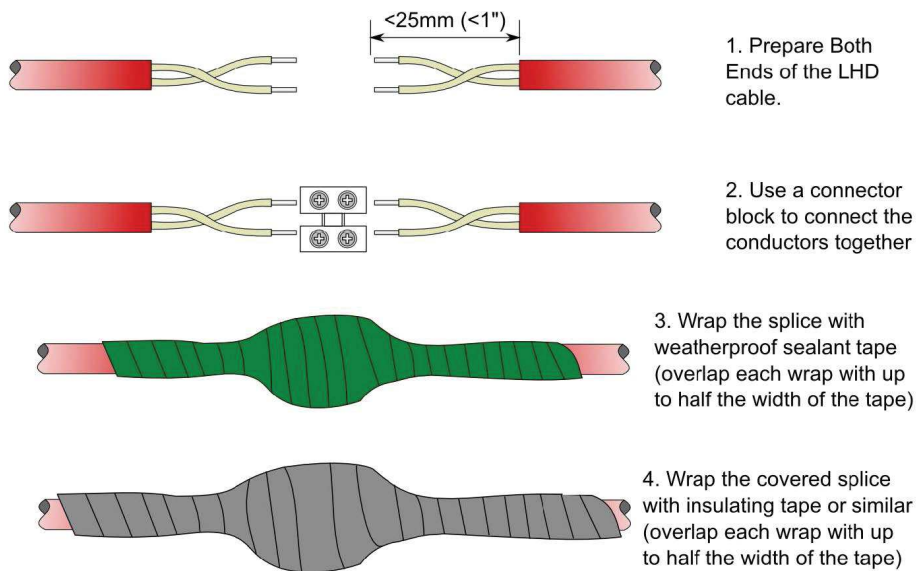

Figure 11: Splicing together joints in LHD cable

Testing and Verification

Routine maintenance and checking should be carried out to ensure the Linear Heat Detection cable will function as expected and has not been damaged etc.

A visual inspection should be performed to ensure all support brackets and other aspects of the physical installation are suitable. The cable should also be visually checked for damage to the outer or inner insulation. Check to make sure the silicone pads are correctly installed around the cable in the clips.

Any joints which have been made should be checked to make sure they are secure and the sealant or insulating tape has not begun to come off. New tape should be applied if necessary.

Electrical tests should be carried out to determine the circuit created by the conductors is working. Remove the conductors from the fire alarm control panel or addressable switch monitor and measuring the resistance across them. The resulting value should equal the end-of-line resistance plus approximately 100Ω/km for each leg.

To test in circuit with a fire alarm control panel or addressable switch monitor re-attach the LHD cable.

Shorting out the End of Line device should put the system into alarm. Disconnecting either leg from the end of line device should put the system into fault.

Functional testing

Fixed Temperature Linear Heat Detection Cable is non-restorable – any section which has alarmed must be cut out and replaced. Therefore functional testing of the installed cable will not normally be carried out.

However, if required, any LHD cable leftover after installation can be used to periodically perform a functional test. A 1m (3ft) section of cable should be attached between the end of the LHD cable run and the end-of-line device.

Using a suitable device heat the test length of detection cable up. Once the action temperature (including any tolerances) has been reached the system should alarm.

Ensure the test length is removed before placing the system back into normal operation.

Chemical Resistance Chart

Chemical	PVC	Nylon	Polypropylene
Ammonia, Liquid	●●●●●	●●●	●●●●●
Butane	●●●●●	●●●●●	●
Copper Nitrate	●●●●●	●	●●●●●
Fuel Oils	●●●●●	●●●●●	●●●
Gasoline	●●	●●●●●	●●
Hydrofluoric Acid	●	●	●●●●●
Kerosene	●●●●●	●●●●●	●
Diesel Fuel	●●●●●	●●●●●	●●●●
Acetic Acid	●●	●	●●●●●

ProReact Digital Linear Heat Detection product range

ALL WEIGHTS IN KG UNLESS OTHERWISE STATED

Part No	Description	100m Reel			200m Reel			500m Reel			1000m Reel		
		Net Wt	Gross Wt	Dimms	Net Wt	Gross Wt	Dimms	Net Wt	Gross Wt	Dimms	Net Wt	Gross Wt	Dimms
F1065	ProReact Digital LHD 68°C PVC	2.04	2.69	ø300mm x 100mm	4.08	4.73	ø300mm x 100mm	10.20	13.00	ø430mm x 135mm	20.41	23.55	ø430mm x 250mm
F1070	ProReact Digital LHD 68°C Nylon outer sheath	2.64	3.29		5.28	5.93		13.21	16.01		26.42	29.56	
F1074	ProReact Digital LHD 68°C Polypropylene outer sheath	2.55	3.20		5.10	5.75		12.75	15.55		25.49	28.63	
F1078	ProReact Digital LHD 68°C Stainless steel outer braid on PVC	3.29	3.94		6.58	7.23		16.44	19.24		N/A		
F1066	ProReact Digital LHD 78°C PVC	2.04	2.69		4.08	4.73		10.20	13.00		20.41	23.55	
F1071	ProReact Digital LHD 78°C Nylon outer sheath	2.64	3.29		5.28	5.93		13.21	16.01		26.42	29.56	
F1075	ProReact Digital LHD 78°C Polypropylene outer sheath	2.55	3.20		5.10	5.75		12.75	15.55		25.49	28.63	
F1079	ProReact Digital LHD 78°C Stainless steel outer braid on PVC	3.29	3.94		6.58	7.23		16.44	19.24		N/A		
F1067	ProReact Digital LHD 88°C PVC	2.04	2.69		4.08	4.73		10.19	12.99		20.38	23.52	
F1072	ProReact Digital LHD 88°C Nylon outer sheath	2.66	3.31		5.31	5.96		13.28	16.08		26.56	29.70	
F1076	ProReact Digital LHD 88°C Polypropylene outer sheath	2.50	3.15		4.99	5.64		12.48	15.28		24.97	28.11	
F1080	ProReact Digital LHD 88°C Stainless steel outer braid on PVC	3.29	3.94		6.57	7.22		16.43	19.23		N/A		
F1068	ProReact Digital LHD 105°C PVC	1.88	2.53		3.76	4.41		9.41	12.21		8.81	21.95	
F1073	ProReact Digital LHD 105°C Nylon outer sheath	2.56	3.21		5.12	5.77		12.81	15.61		25.61	28.75	
F1077	ProReact Digital LHD 105°C Polypropylene outer sheath	2.46	3.11		4.92	5.57		12.29	15.09		24.58	27.72	
F1081	ProReact Digital LHD 105°C Stainless steel outer braid on PVC	3.13	3.78		6.26	6.91		15.64	18.44		N/A		
F1069	ProReact Digital LHD 185°C Nylon outer sheath	1.79	2.44	3.59	4.24	8.97	11.77	17.94	21.08				
F1082	ProReact Digital LHD 185°C Stainless steel outer braid on Nylon	3.04	3.69	6.08	6.73	15.21	18.01	N/A					
A1077	Digital location control unit (Metric gland knockouts)	653g		180mm x 130mm x 78mm									
A1349	ProReact Digital interface Monitor Module (DiMM)	673g		180mm x 120mm x 61mm									

ASTEC_{B.V.}

Kerkweg 70
6155 KN Puth (NL)
Tel.: +31 (0)46 443 55 77
Fax: +31 (0)46 443 04 82
E-mail: info@astec.nl
Internet: www.astec.nl