

## Infrared Hydrocarbon Gas Detector Open Path Eclipse™ Model OPECL

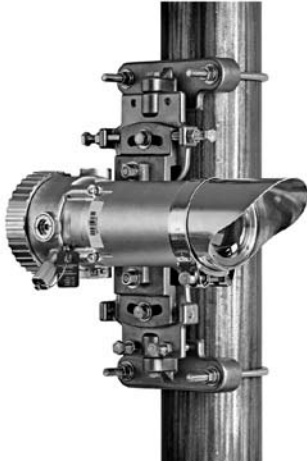

### DESCRIPTION

The Open Path Eclipse™ Model OPECL is an open path infrared gas detection system that provides continuous monitoring of combustible hydrocarbon gas concentrations in the range of 0 to 5 LFL-meters, over a distance of 5 to 120 meters. Standard system outputs include an electrically isolated/non-isolated 4-20 mA dc current output, with HART and RS-485 MODBUS communication. Alarm and fault relays are available as an option. A LON based model (with no analog or relay outputs) is available for use with Eagle Quantum Premier® systems.

The OPECL IR Gas Detector delivers superior open path combustible gas detection for protection of oil/gas and other industrial facilities. The Open Path Eclipse system is especially useful for perimeter monitoring and applications where combustible gas/vapor leaks can happen over a widely dispersed area.

The Model OPECL system offers industry leading features including dual xenon flashlamps, stainless steel construction, ease of installation and alignment, field replaceable transmitter and receiver modules, and a standard 2 year warranty.

The system is optimized for low maintenance, no false alarms, and low cost. The OPECL system utilizes onboard heaters in both modules to melt snow and ice, enabling unattended and uninterrupted operation in inclement weather.

Det-Tronics Model OPECL is approved for use in Class I, Div. 1, IECEx, EExe and Zone 1 hazardous areas.

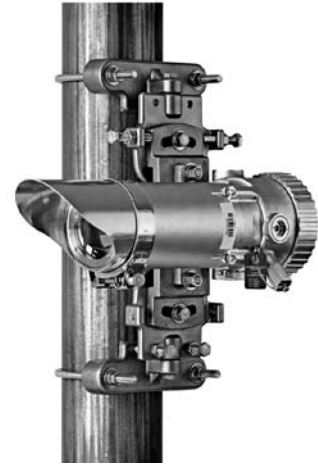

### FEATURES AND BENEFITS

- Detects methane and most hydrocarbon gases including ethane, propane, butane, and propylene
- 5-120 meter separation distance
- Certified explosion-proof for use in Class I, Div. 1 and Div. 2, and Zone 1 and Zone 2 hazardous areas
- Performance approved
- Ideal for use in harsh outdoor environments
- Heated optics
- Continuous self-check for immediate notification of internal failure
- Signals operator in case of blocked or impaired optical conditions
- Reliable performance in the presence of oil mist, glycol, salt water
- Stainless steel construction
- No filter wheel motors or other moving parts
- Integral terminal wiring compartment
- Optional relay output board
- Tri-color onboard LED indicates system status
- Internal magnetic reed switch for non-intrusive calibration
- I.S. HART port supports HART and AMS communication menus
- Compatible with UD10 for readout of device status
- EQP compatible version available

## SPECIFICATIONS

<b>Input Voltage (Both Modules)</b>	24 Vdc nominal. Operating range is 18 to 30 Vdc. Ripple cannot exceed 0.5 volts P-P.
<b>Power Consumption</b>	<p><b>Transmitter</b> 5.0 watts nominal @ 24 Vdc, 6.9 watts @ 30 Vdc. 5.8 watts peak @ 24 Vdc, 7.5 watts peak @ 30 Vdc.</p> <p><b>Receiver Without Relays</b> 6.0 watts nominal @ 24 Vdc, 7.6 watts nominal @ 30 Vdc.</p> <p><b>Receiver With Relays</b> 6.4 watts nominal @ 24 Vdc, 8.0 watts nominal @ 30 Vdc.</p>
<b>Transmitter Lamps</b>	Two xenon flashlamps, field-replaceable module.
<b>Warm-up Time</b>	1 minute for transmitter. 30 seconds for receiver from power-up when correctly aligned.
<b>Current Output</b>	Linear 4-20 mA (isolated/non-isolated) rated at 600 ohms maximum loop resistance @ 24 Vdc operating voltage. A LON based model (with no analog or relay outputs) is available for use with EQP systems.
<b>Visual Status Indicator</b>	Tri-color LED: Red = Alarm or calibration (receiver only) Green = Power on / OK Amber = Fault / warm-up
<b>Relay Setpoint Range</b>	Low Alarm: 0.25 to 3 LFL-meters (default = 1 LFL-meter) High Alarm: 1 to 3 LFL-meters (default = 2 LFL-meters)
<b>Detection Range</b>	5 to 120 meters
<b>Calibration</b>	Calibrated for methane at the factory.
<b>Response Time</b>	T90: <5 seconds Note: Add 2 seconds for EQP models.
<b>Accuracy</b>	±0.25 LFL-meters or ±10% of applied gas concentration, whichever is greater.
<b>Temperature Range</b>	Operating: -40°C to +60°C (-40°F to +140°F) Storage: -55°C to +85°C (-67°F to +185°F)
<b>Humidity</b>	5 to 99% RH; designed for outdoor applications.
<b>Measurement Range</b>	0-5 LFL-meters
<b>Interference Resistance</b>	Immune to sun and flare radiation, up to 750 W/m <sup>2</sup> ≥ 3° to optical axis and common contaminants.
<b>Self-Diagnostic Test</b>	Fail-Safe operation ensured by performing all critical tests once per second.
<b>Module Housing Material</b>	316 stainless steel (CF8M)

<b>Conduit Entries</b>	Two entries, 3/4 inch NPT or 25 mm
<b>HART Port</b>	Intrinsically safe port on receiver to connect HART devices.
<b>Optics Protection</b>	Stainless steel brow protects against windblown dirt and rain. Heated optics minimize ice and dew formation.
<b>Wiring</b>	Field wiring screw terminals are UL/CSA rated for up to 14 AWG wire, and are DIN/VDE rated for 2.5 mm <sup>2</sup> wire. Receiver can be wired using 3 or 4 wires. Transmitter requires two wires (power only).
<b>Shipping Weight</b>	Each module, with mounting hardware: 35 pounds (16 kg)
<b>Certification</b>	<p>CSA: Class I, Div. 1, Groups B, C &amp; D (T5). Class I, Div. 2, Groups A, B, C &amp; D (T4). NEMA/Type 4X. Conduit seal not required.</p> <p>FM: Class I, Div. 1, Groups B, C &amp; D (T5). Class I, Div. 2, Groups A, B, C &amp; D (T4). NEMA/Type 4X. Conduit seal not required. Performance verified in accordance with FM 6325, ANSI/ISA 12.13.04.</p> <p>ATEX: <b>CE</b> 0539  II 2 G DEMKO 06 ATEX 141002X EEx de [ib] IIC, T5. T5 (T<sub>amb</sub> -40°C to +60°C). IP67. (Transmitter, Receiver without relays) --OR-- EEx d [ib] IIC, T5 T5 (T<sub>amb</sub> -55°C to +60°C). IP67. (Receiver with relays) Performance verified in accordance with EN 50241-1 and EN 50241-2.</p> <p>CE: Conforms to: Low Voltage Directive: 2006/95/EC, EMC Directive: 2004/108/EC, ATEX Directive: 94/9/EC, WEEE 2002/96/EC.</p> <p>IECEX: ULD 05.0001X Ex d [ib] IIC T5 or Ex de [ib] IIC T5.</p>
<b>Dimensions</b>	<p>Modules— Length: 14.3 in (36.3 cm) Diameter: 4.5 in (11 cm) max</p> <p>Mounting Plate— Height: 14.5 in (36.8 cm) Width: 6 in (15 cm)</p> <p>Designed to affix to 4 inch (10 cm) nominal diameter pipe.</p>
<b>Warranty</b>	2 year limited warranty from date of manufacture.



Specifications subject to change without notice.

Det-Tronics, the DET-TRONICS logo, and Eclipse are registered trademarks or trademarks of Detector Electronics Corporation in the United States, other countries, or both. Other company, product, or service names may be trademarks or service marks of others.

©Copyright Detector Electronics Corporation 2009. All rights reserved.



### Detector Electronics Corporation

6901 West 110th Street • Minneapolis, Minnesota 55438 USA

Operator: (952) 941-5665 or (800) 765-FIRE

Customer Service: (952) 946-6491 • Fax (952) 829-8750

http://www.det-tronics.com • E-mail: det-tronics@det-tronics.com